



SAFE & VAULT MANUFACTURERS

# BLISTER STAND



## FEATURES

- Stand 800mm high.
- Secured by 4 x 12mm bolts to the floor.
- Blister safe secured by 4 x 10mm stud and nuts in back of safe with 2 x 12mm bolts in base of safe.

| Model              | Height mm | Width mm | Depth mm |
|--------------------|-----------|----------|----------|
| <b>STAND-G-KC1</b> | 800       | 600      | 452      |

MODEL STAND-G-KC1



**THIS CMI SAFE ACCESSORY COMES WITH A FIVE YEAR WARRANTY, EXCLUDING FREIGHT AND TRAVELLING.**



**MADE IN AUSTRALIA**



SAFE & VAULT MANUFACTURERS

# BLISTER STAND



MODEL STAND-G-KC1 - TOP



MODEL STAND-G-KC1 - FRONT

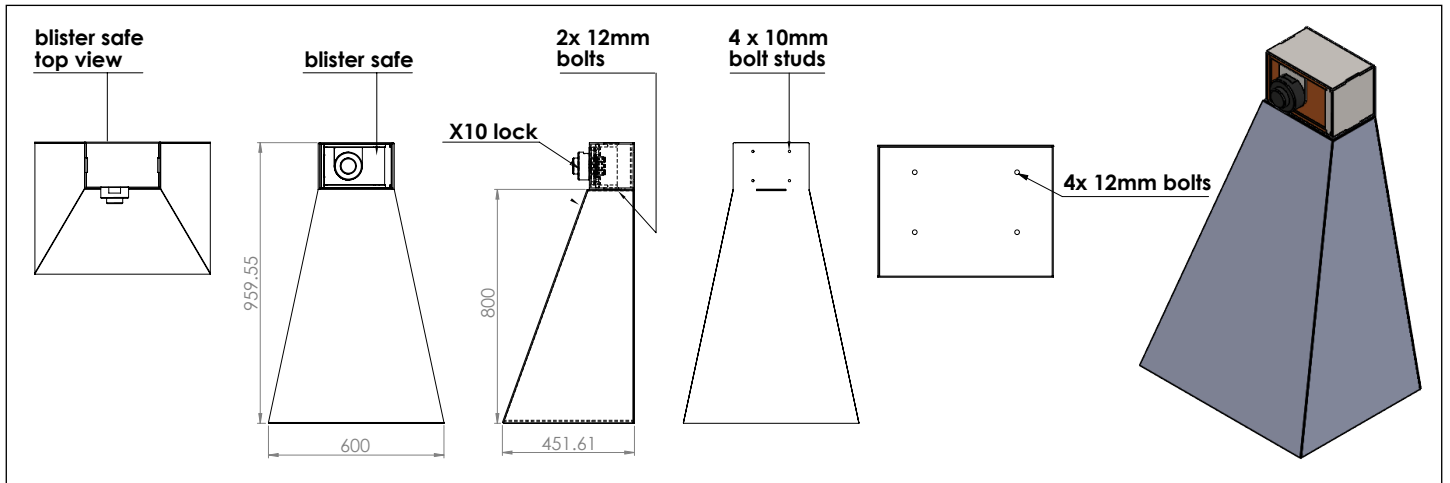

Accessory to be used with the SCEC-approved G-KC1 Safe.  
Installation of the GKC-1 is in accordance with working note 1-84.



CMI Safe Co  
ABN | 35 664 874 766

☎ 02 9547 1488  
✉ sales@cmisafe.com.au

📍 244 West St | Carlton | NSW | 2218  
🌐 www.cmisafe.com.au



## MADE IN AUSTRALIA

CD DZ 00353 270526