



SAFE & VAULT MANUFACTURERS



STRONGROOM DOOR & FRAME

AS1428.1 2009 APPROVED DOORS



MODEL G-CDB4



AS1428.1 2009 approved doors



MADE IN AUSTRALIA



SAFE & VAULT MANUFACTURERS



STRONGROOM DOOR & FRAME

ASI428.1 2009 APPROVED DOORS

MODEL G-CDB4



FEATURES

- Secured each side and top by 11 x 32mm locking bolts.
- Overall door thickness of 174mm including fire pan.
- Emergency internal release mechanism fitted as standard.
- Glass activated deadlocking devices are provided within the door as standard.
- Full hard plate protection over all vital areas.
- Several micro switches installed as standard to confirm status of all possible entry points.
- Locking by KABA X10 lock, no batteries required.



Model	Clear Door Opening		Clear Masonry Opening Required		Weight
	Height mm	Width mm	Height mm	Width mm	
G-CDB4	1980	860	2060	1020	495kg

When ordering state if left or right hand hinging required and existing wall thickness.



Class B SCEC Strongroom Door and Frame designed to be fire resisting for one hour



ALL CMI SAFES COME WITH A FIVE YEAR WARRANTY, EXCLUDING FREIGHT AND TRAVELLING, WITH A 24 MONTH WARRANTY ON LOCKS.

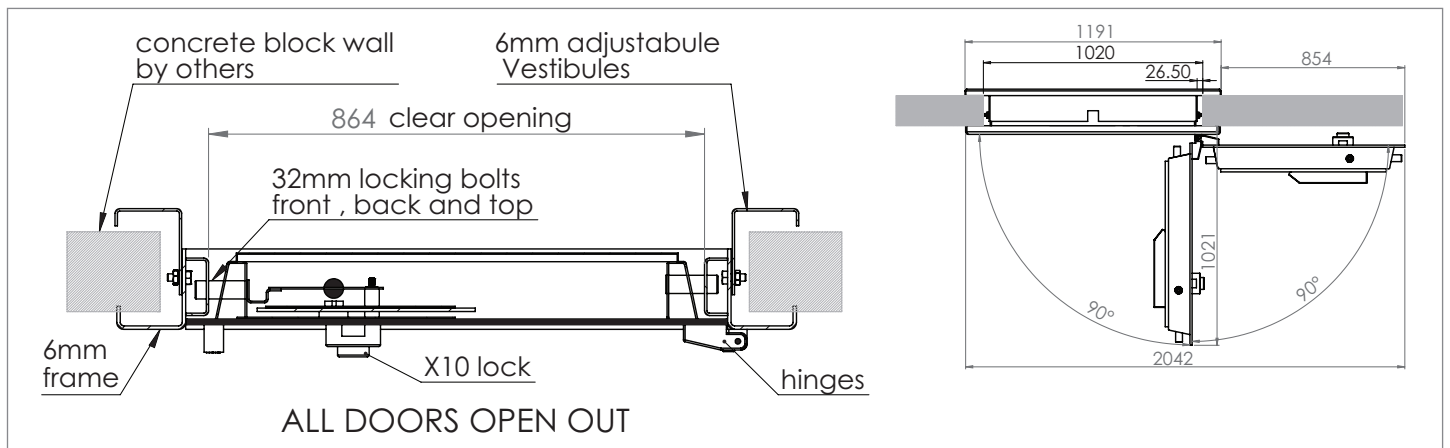

CMI Safe Co
ABN | 35 664 874 766

☎ 02 9547 1488
✉ sales@cmisafe.com.au

📍 244 West St | Carlton | NSW | 2218
🌐 www.cmisafe.com.au



MADE IN AUSTRALIA

CD DZ 00309 130326