



SAFE & VAULT MANUFACTURERS



# STRONGROOM DOOR & FRAME

AS1428.1 2009 APPROVED DOORS



MODEL  
G-CDB4



AS1428.1 2009  
approved doors



**MADE IN AUSTRALIA**



# STRONGROOM DOOR & FRAME

ASI428.1 2009 APPROVED DOORS

SAFE & VAULT MANUFACTURERS

MODEL G-CDB4



## FEATURES

- Secured each side and top by 11 x 32mm locking bolts.
- Overall door thickness of 174mm including fire pan.
- Emergency internal release mechanism fitted as standard.
- Glass activated deadlocking devices are provided within the door as standard.
- Full hard plate protection over all vital areas.
- Several micro switches installed as standard to confirm status of all possible entry points.
- Locking by KABA X10 lock, no batteries required.



Model	Clear Door Opening		Clear Masonry Opening Required		Weight
	Height mm	Width mm	Height mm	Width mm	
<b>G-CDB4</b>	1980	860	2060	1020	495kg

When ordering state if left or right hand hinging required and existing wall thickness.



**Class B SCEC Strongroom Door and Frame designed to be fire resisting for one hour**



**ALL CMI SAFES COME WITH A FIVE YEAR WARRANTY, EXCLUDING FREIGHT AND TRAVELLING, WITH A 24 MONTH WARRANTY ON LOCKS.**

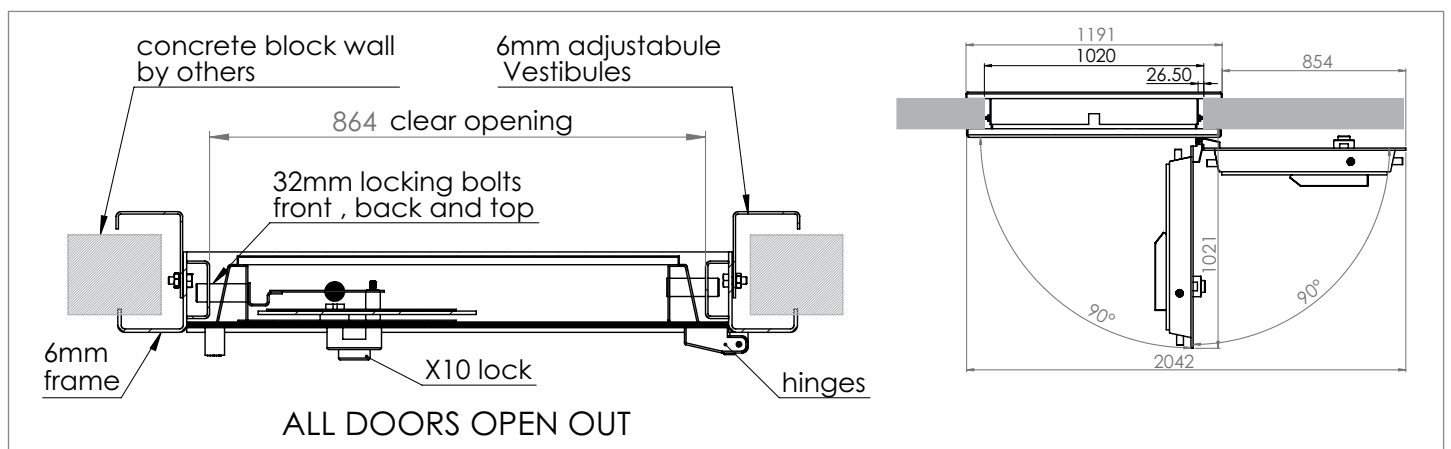

CMI Safe Co  
ABN | 35 664 874 766

☎ 02 9547 1488  
✉ sales@cmisafe.com.au

📍 244 West St | Carlton | NSW | 2218  
🌐 www.cmisafe.com.au



**MADE IN AUSTRALIA**

CD DZ 00309 201024