

CLASS 'B' **SCEC**
APPROVED

STRONGROOM DOOR & FRAME



FOR THE
**SECURITY
CONSCIOUS**



■ **MODEL G-CDB4**



AS1428.1 2009
APPROVED DOORS



MADE IN AUSTRALIA



STRONGROOM DOOR & FRAME

ALL CMI SAFES COME WITH A FIVE YEAR WARRANTY, EXCLUDING FREIGHT AND TRAVELLING, WITH A 24 MONTH WARRANTY ON LOCKS.

FEATURES

- Secured each side and top by 11 x 32mm locking bolts.
- Overall door thickness of 174mm including fire pan.
- Emergency internal release mechanism fitted as standard.
- Glass activated deadlocking devices are provided within the door as standard.
- Several micro switches installed as standard to confirm status of all possible entry points.
- Full hard plate protection over all vital areas.
- Locking by KABA X10 lock, no batteries required.



AS1428.1 2009
APPROVED DOORS

MODEL **G-CDB4**



CLASS 'B' STRONGROOM DOOR AND FRAME DESIGNED TO BE FIRE RESISTING FOR ONE HOUR

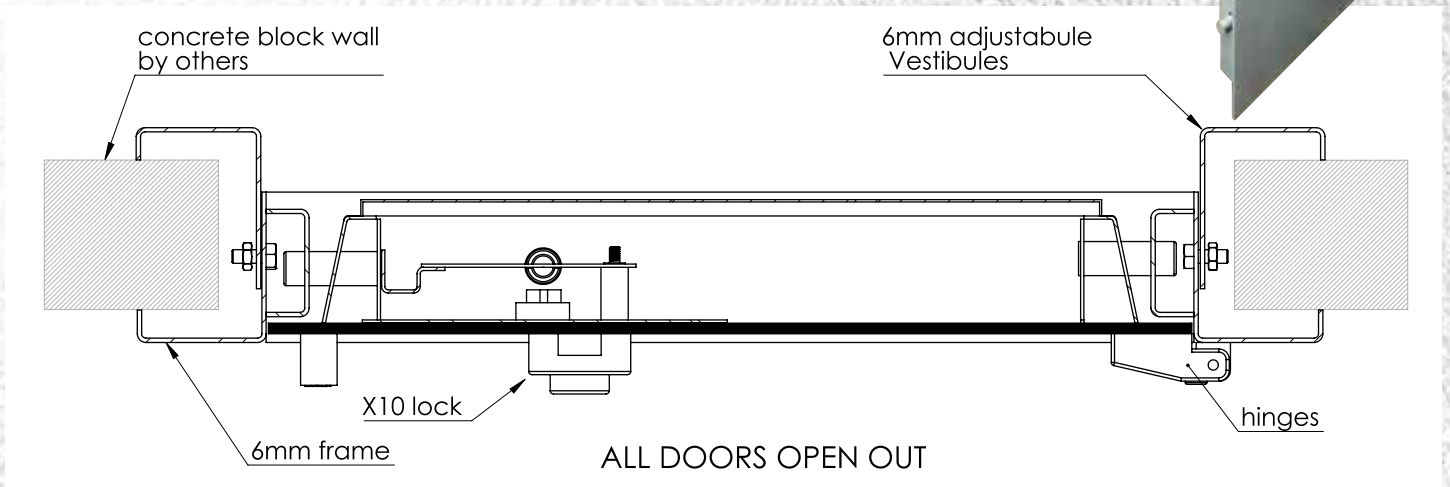

MODEL	PRICE INCL. GST	CLEAR DOOR OPENING		CLEAR MASONRY OPENING REQUIRED		WEIGHT	DELIVERY & INSTALLATION LEVEL ACCESS INCL. GST
		HEIGHT	WIDTH	HEIGHT	WIDTH		
G-CDB4	\$	1980 mm	860 mm	2060 mm	1020 mm	495kg	\$

WHEN ORDERING PLEASE STATE IF LEFT OR RIGHT HAND HINGING REQUIRED AND EXISTING WALL THICKNESS.

CMI SAFE CO. ABN 20 118 637 245

Head Office: 244 West Street, Carlton NSW 2218
 Phone: (02) 9547 1488 Fax: (02) 9547 2104
 Website: www.cmisafe.com.au
 Email: sales@cmisafe.com.au

AVAILABLE FROM

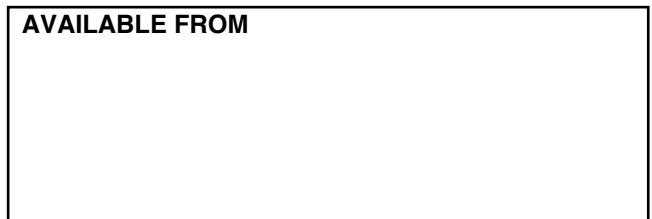

MADE IN AUSTRALIA